



D50 L / D105 L 32 AUTO

Tritacarne / Meat mincer

D50 L 32 AUTO



D105 L 32 AUTO

2

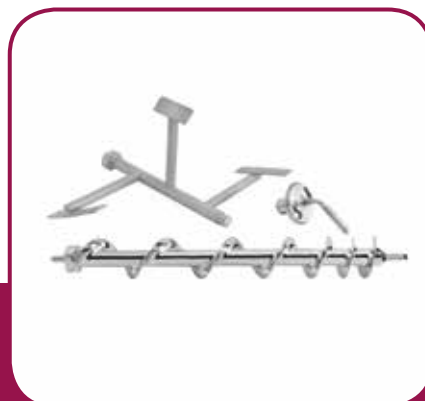

DOTAZIONI DI SERIE

- Robusto e silenzioso
- Costruito completamente in acciaio inox 18-10
- 2 motori separati, il primo per tritare il secondo per mescolare
- Sistema di taglio singolo o doppio disponibile
- Su richiesta è possibile avere il sistema di taglio triplo che prevede 3 piastre e 2 coltelli
- Pale mescolatrici
- Facilità per lo scarico prodotto
- Facilità nella pulizia

STANDARD EQUIPMENT

- Heavy duty and silent
- Entirely in stainless steel 18-10
- 2 motor reducers, the first one for mincing and the second one for mixing
- Cutting system: enterprise or unger
- The triple cut option is available - possible use with an extra blade and knife on the unger system
- Mixing arm
- Easily unloaded
- Very easy to clean

D50 L 32 AUTO

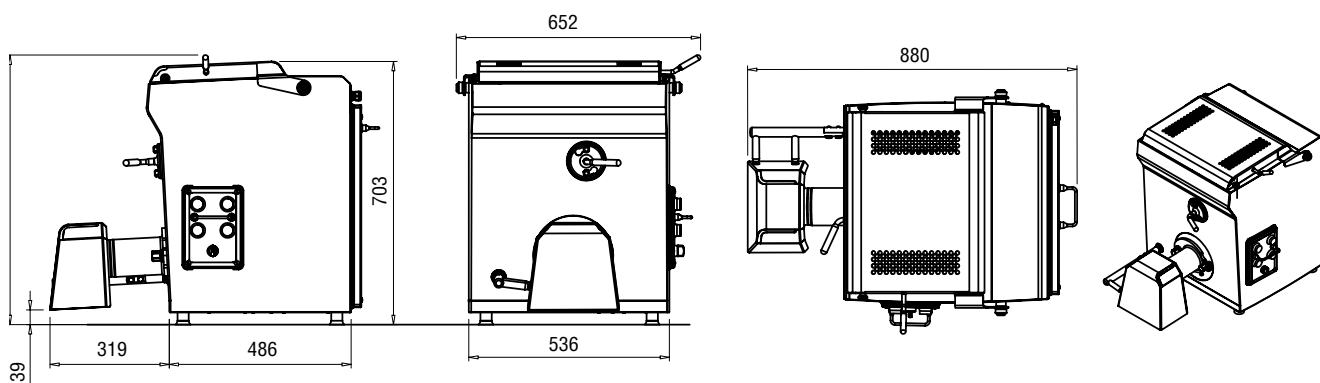

D105 L 32 AUTO

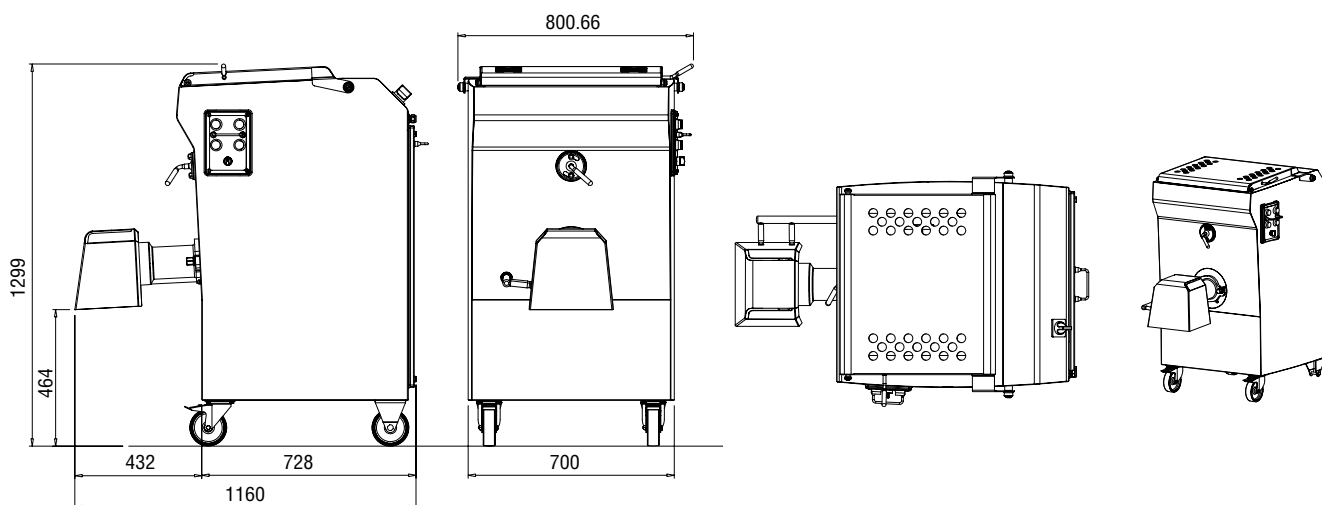

SPECIFICHE TECNICHE / TECHNICAL SPECIFICATION		D50 L 32 AUTO	D 105 L 32 AUTO
Produzione oraria kg/h	<i>Hourly output kg/h</i>	600	1000
Alimentazione	<i>Power source</i>	TRIFASE, 400V, 50 hz	TRIFASE, 400V, 50 hz
Motore tritacarne	<i>Mincer motor power</i>	2 CV (1,5 Kw)	5,5 CV (4 Kw)
Motore impastatrice	<i>Mixing motor power</i>	0,75 CV (0,55 Kw)	1,5 CV (1,1 Kw)
Capacità vasca	<i>Hopper capacity</i>	50 L	105 L
Piastra diametro	<i>Grate's diameter</i>	5 mm	5 mm
Peso macchina	<i>Machine's weight</i>	90 kg	150 kg