



TK 22 / 32

Tritacarne / Meat mincer



DOTAZIONI DI SERIE

- Tritacarne professionali entry-level
- Struttura in acciaio inox aisi 304
- Riduttore con vite senza fine
- Gruppo di macinazione in acciaio inox
- Disponibile sistema di taglio unger a 3 o 5 elementi
- Bloccaggio laterale del gruppo di macinazione
- Comandi laterali
- Tramoggia in acciaio inox
- Motori ventilati monofase o trifase
- Comandi a bassa tensione. Nvr

STANDARD EQUIPMENT

- Professional entry-level meat mincers
- Aisi 304 stainless steel body
- Endless screw motor reducer
- Stainless steel mincing group
- 3 - or 5 - elements unger cutting set, on request
- Side blocking of the mincing group
- Side panel control
- Stainless steel hopper
- 1-phase or 3 - phase motor
- Low voltage controls. Nvr

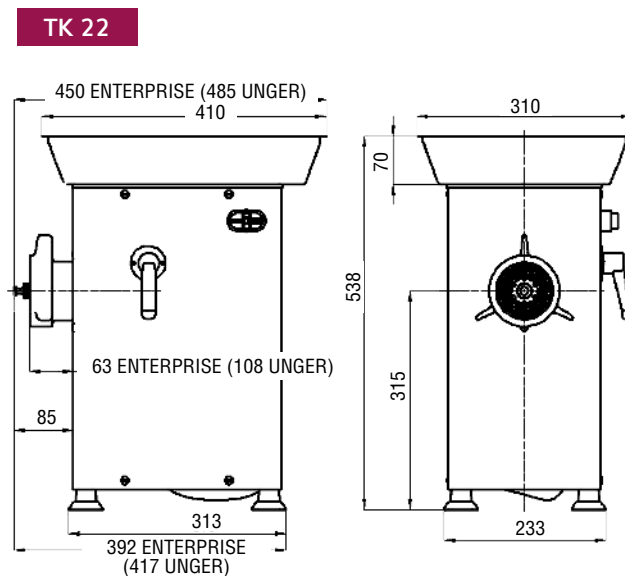

SPECIFICHE TECNICHE TECHNICAL SPECIFICATION		TK 22	
Tensione di alimentazione	<i>Power source</i>	Monofase 230V - Trifase 400V	
Potenza motore	<i>Motor power</i>	1,1 kW (1,5 HP) Monofase & trifase	
Assorbimento	<i>Electrical absorption</i>	4A Monofase - 2A Trifase	
Livello di rumorosità	<i>Sound power level</i>	58 dBA	
Temperatura di impiego	<i>Temperature</i>	5°C - 35°C	
Struttura	<i>Frame</i>	Inox AISI 304	
Grado di protezione	<i>Protection degree</i>	IP 53	
Produzione oraria	<i>Output / h</i>	300 kg	
Dimensioni mm	<i>Dimensions mm</i>	210 x 410 x 450	
Peso netto	<i>Net weight</i>	25 kg	
Peso imballato	<i>Gross weight</i>	27 kg	