

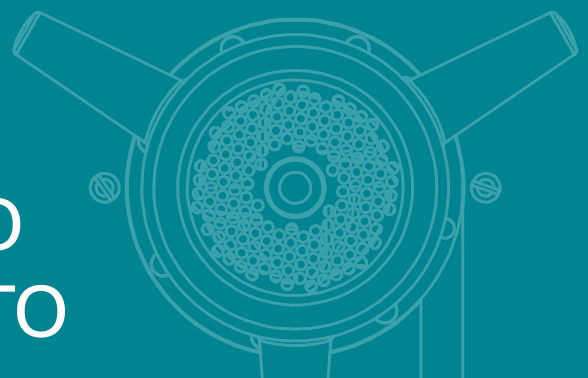

Since 1971



IKO 32
IKO 32 XL
IKO 32 FREDDO
TCY 32 GD AUTO





TRITACARNE MEAT MINCERS

I tritacarne professionali ABM sono attrezzature adatte per diverse situazioni di lavoro dal piccolo laboratorio ai supermercati, sino alle mense e grandi ipermercati.

The ABM professional meat mincers are suitable equipment for various working area from the small laboratory to the supermarkets up to canteens and large hypermarkets.



La gamma dei tritacarne ABM si suddivide in tre grandi famiglie: le macchine da banco dalla capacità produttiva ideale per negozi e cucine, le macchine da terra con la funzione anche di impastatrice, le macchine ABM adatte per grandi volumi.

Tutti i tritacarne sono realizzati in acciaio inox e sono progettati per essere produttivi e resistenti nel tempo.

Le macchine da banco sono completamente smontabili per una semplice pulizia.

Il motore è trifase o monofase con comandi di attivazione a bassa tensione.

Le macchine da terra hanno la funzione ulteriore di impastatrice con differenti capacità di carico e di lavoro.

Anche questi modelli sono facilmente accessibili per potere procedere alle fasi di manutenzione e pulizia ordinaria.

Tutti i tritacarne ABM sono conformi alle normative CE in materia di igiene e sicurezza.

The ABM meat grinder range is made up of three large families: the bench-top machine, ideal for shops and kitchens, the floor machines with the kneader feature as well, ABM machine suitable for continuous intensive operation.

All the mincers are stainless steel machines, long life and heavy-duty body.

Bench-top meat mincers can be completely disassembled for easy cleaning.

The motor is three-phase or single-phase with low voltage controls.

The floor meat mixers have the additional function of mixing machine with different load capacities.

Those models are friendly use, easily cleaning for the ordinary maintenance.

ABM meat mincers meet the requirement of the applicable EC directives - CE marking.





IKO 32

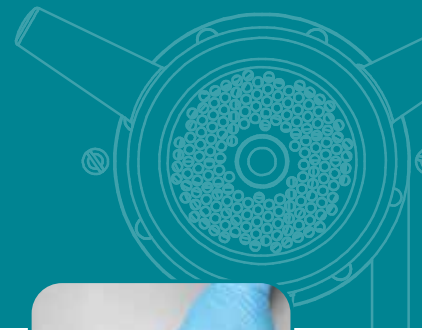

DOTAZIONI DI SERIE

- Tritacarne professionale da banco
- Trifase – monofase su richiesta
- Struttura in acciaio inox Aisi 18-10
- Gruppo di macinazione in acciaio inox
- Riduttore a bagno d'olio
- Pulsanti marcia/arresto/reverse IP69
- Tramoggia standard smontabile
- Sistema entreprise
- Comandi laterali
- Conforme alle normative CE e alle normative internazionali

STANDARD EQUIPMENT

- Professional table top mincer
- 1 phase or 3 phase on demand
- Stainless steel body
- Stainless steel mincing assembly
- Oil bath sealed box
- IP69 switches start/stop/reverse
- Removable standard hooper
- Entreprise system
- Control panel on the side
- Safety: complies with European and international standards

OPTIONAL

- Tramoggia maggiorata

OPTIONAL

- Bigger hooper

IKO 32

DIMENSIONI | DIMENSIONS

SPECIFICHE TECNICHE / TECHNICAL SPECIFICATION

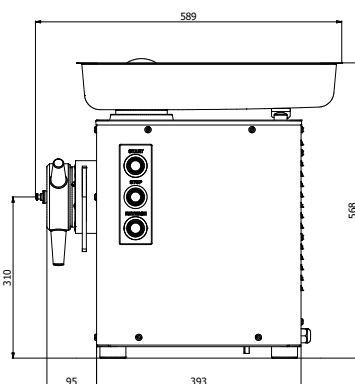

Produzione kg/h – Output kg/h	400 approx
3 phase Motore/Motor power	3 cv – 2.2 kw
1 phase Motore/Motor power	3 cv – 2.2 kw con/with inverter
Alimentazione/Power source	3 phase 400V /50Hz – 1 phase 230V /50 hz
Piastra standard diametro/ standard plate's diameter	4.5 mm
Peso kg/Machine's weight	68 kg



IKO 32 XL



DOTAZIONI DI SERIE

- Tritacarne professionale
- Trifase – monofase su richiesta
- Struttura in acciaio inox Aisi 18-10
- Gruppo di macinazione in acciaio inox
- Riduttore a bagno d'olio
- Pulsanti marcia/arresto/reverse IP69
- Tramoggia smontabile maggiorata
- Sistema entreprise
- Comandi laterali
- Tavolo supporto con ruote
- Conforme alle normative CE e alle normative internazionali

STANDARD EQUIPMENT

- Professional mincer
- 1 phase or 3 phase on demand
- Stainless steel body
- Stainless steel mincing assembly
- Oil bath sealed box
- IP69 switches start/stop/reverse
- Bigger removable hooper
- Entreprise system
- Control panel on the side
- Support table with wheels
- Safety: complies with European and international standards

IKO 32 XL

DIMENSIONI | DIMENSIONS

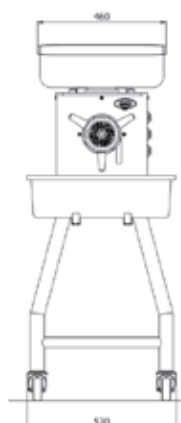
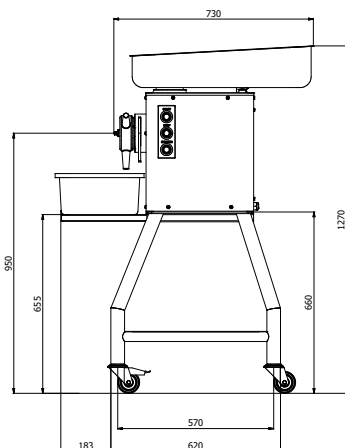

SPECIFICHE TECNICHE / TECHNICAL SPECIFICATION

Produzione kg/h – Output kg/h	400 approx
3 phase Motore/Motor power	3 cv – 2.2 kw
1 phase Motore/Motor power	3 cv – 2.2 kw con/with inverter
Alimentazione/Power source	3 phase 400V /50Hz – 1 phase 230V /50 hz
Piastra standard diametro/ standard plate's diameter	4.5 mm
Peso kg/Machine's weight	89 kg



IKO 32 FREDDO



DOTAZIONI DI SERIE

- Tritacarne professionale da banco
- Trifase
- Struttura in acciaio inox Aisi 18-10
- Gruppo di macinazione in acciaio inox
- Riduttore a bagno d'olio
- Pulsanti marcia/arresto/reverse IP69
- **Gas R290 - nuove normative CE** (0,03 kg)
- Intervallo di temperatura: 1-3 °C
- Tramoggia standard smontabile
- Sistema enterprise
- Comandi laterali
- Conforme alle normative CE e alle normative internazionali

STANDARD EQUIPMENT

- *Professional table top mincer*
- *3 phase*
- *Stainless steel body*
- *Stainless steel mincing assembly*
- *Oil bath sealed box*
- *IP69 switches start/stop/reverse*
- **R290 gas - new CE regulations** (0,03 kg)
- *Temperature range: 1-3 °C*
- *Removable standard hooper*
- *Enterprise system*
- *Control panel on the side*
- *Safety: complies with European and international standards*

IKO 32 FREDDO | DIMENSIONI | DIMENSIONS

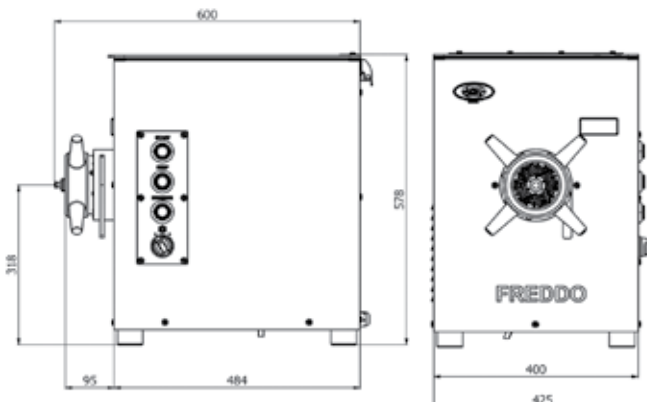

SPECIFICHE TECNICHE / TECHNICAL SPECIFICATION

Produzione kg/h – Output kg/h	400 approx
3 phase Motore/Motor power	3 cv – 2.2 kw
Alimentazione/Power source	3 phase 400V /50Hz
Piastra standard diametro/ standard plate's diameter	4.5 mm
Peso (lordo/netto) Machine's weight (gross/net)	108 kg / 90 kg



TCY 32 GD AUTO

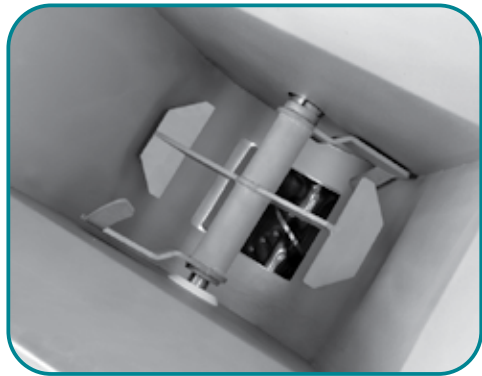

DOTAZIONI DI SERIE

- Tritacarne e mescolatore professionale automatico
- Da pavimento, carrellato
- Struttura in acciaio inox aisi 304
- Gruppo di macinazione e pala mixer smontabili facilmente per una migliore pulizia
- Tramoggia asportabile
- Macinazione e miscelazione alimentate da due motori indipendenti
- Comando a pedale incluso
- Inversione di marcia

STANDARD EQUIPMENT

- Professional auto meat mincer and mixer grinder
- Floor wheeled
- Aisi 304 stainless steel body
- Mincing set and paddle easily removable for quick cleaning
- Removable hopper
- Grinding and mixing unit activated by two independent motors
- Foot pedal control included
- Reverse push button

TCY 32 GD AUTO

DIMENSIONI | DIMENSIONS

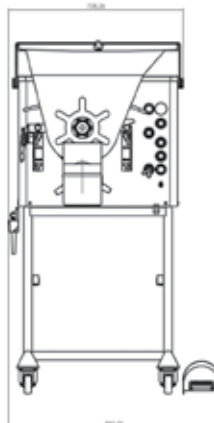
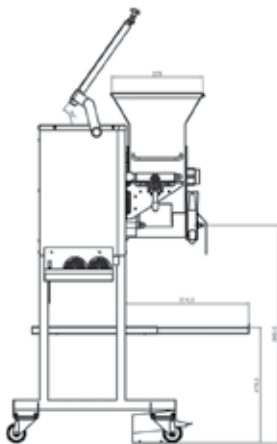
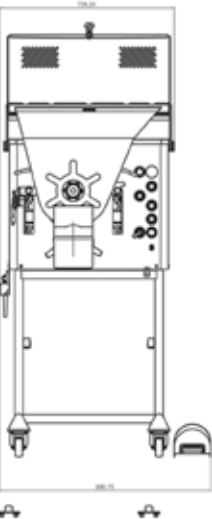

SPECIFICHE TECNICHE / TECHNICAL SPECIFICATION

Produzione oraria kg/h <i>Hourly output kg/h</i>	750
Potenza motore kw <i>Motor power kw</i>	2,2
Macinazione/miscelazione <i>mincer/mixer</i>	0,75
Capacità vasca L <i>Bowl capacity L</i>	45
Dimensioni imballo <i>Packing dimension mm</i>	729 x 880 x 1459 ht
Peso/Weight	170 kg

Enjoy the spirit of ABM



ITALIA - Via Rho, 6 - 20045 Lainate (MI) - Italy
T. +39 02 9373781 - F. +39 02 93790148 - abm@abmcompany.com
www.abmcompany.com

