

MOD 72

Cubettatrice / Dicer

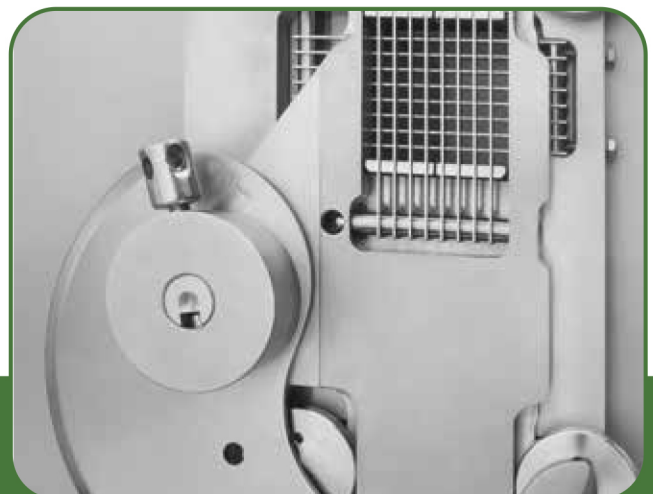

DOTAZIONI DI SERIE

- Macchina da banco
- Completamente in acciaio inox
- Fornita di una griglia di taglio standard in acciaio inox a scelta fra 8x8 mm e 24x24 mm
- Robustissime griglie di taglio in acciaio inox su richiesta: 9x9mm, 18x18 mm, 36x36mm
- Ideale per produrre cubetti, fettine, julienne, scaglie e dadini
- Avanzamento idraulico

STANDARD EQUIPMENT

- *Top cutting quality table machine*
- *Entirely stainless steel*
- *Different cube sizes are possible due to various stainless steel gridsets: 8x8 mm and 24x24 mm in stock*
- *9x9 mm, 18x18 mm and 36x36 mm, gridsets on request*
- *Ideal for the productin of cubes, minced meat, strips, tartar, giros, shawarma and vegetables*
- *Hydraulics advance*

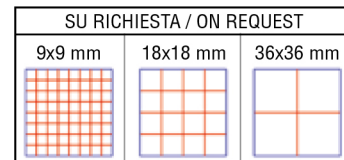
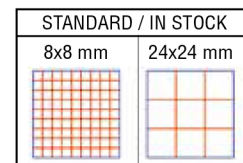
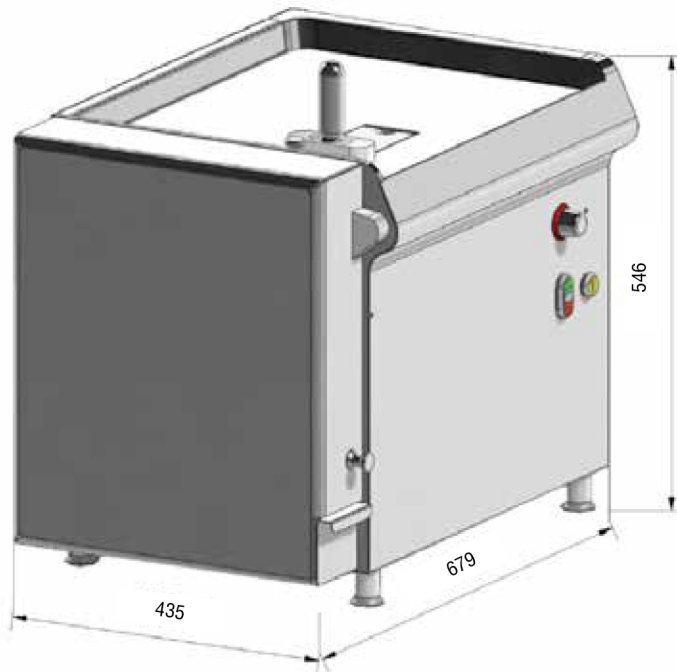

SPECIFICHE TECNICHE / TECHNICAL SPECIFICATION

Capacità di taglio	<i>Chamber size 72 x 72 x 200 mm</i>	(circa /about 1 kg)
Portata media	<i>Average output</i>	2 Kg / min
Potenza coltelli	<i>Knives power</i>	0,75 kw
Avanzamento regolabile	<i>Adjustable advance</i>	1 a 60 mm
Potenza avanzamento	<i>Advanced power</i>	0,55 kw
Velocità di taglio	<i>Blade speed</i>	145 tagli/ min
Motore	<i>Motor power</i>	400 V Trifase + neutro
Dimensioni	<i>Sizes</i>	435 x 679 x 546
Peso netto	<i>Weight</i>	122.5 kg