



# UNI 350 G

Affettatrice gravità / Gravity slicer



3<sup>RD</sup>  
GENERATION  
BLADE

BY CHOICE

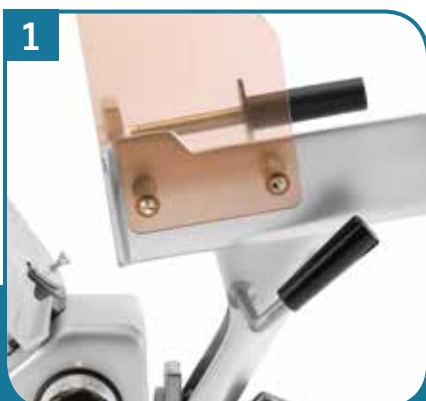

## DOTAZIONI DI SERIE

- Trasmissione a cinghia
- Affilatoio incorporato o separato di facile impiego
- Altezza di carico ridotta che facilita il lavoro dell'operatore
- Lama 3° generazione
- Piatto portamerce ribaltabile con pressamerce in alluminio
- Base di appoggio piedini ridotta
- Accurati canalini per una maggiore scorrevolezza del prodotto
- Pulsanti marcia/arresto IP 69
- Affilatoio e coprilama asportabili per un'accurata pulizia

## OPTIONAL

- Trasmissione ad ingranaggi
- Manopole in alluminio
- Lama estraibile
- Sollevatore

## STANDARD EQUIPMENT

- Belt transmission
- Integrated or separated sharpener friendly use
- Reduced loading height to simplify the operator's daily work
- 3rd generation blade
- Upsetting product plate with an aluminium product pusher
- Reduced cradle feet
- Improved guide ridges for a better running product
- IP69 switches: vandal - proof and life time warranty
- Removable sharpener and blade, easy cleaning

## OPTIONAL

- Gear transmission
- Aluminium handles
- Blade remover
- Tilting device

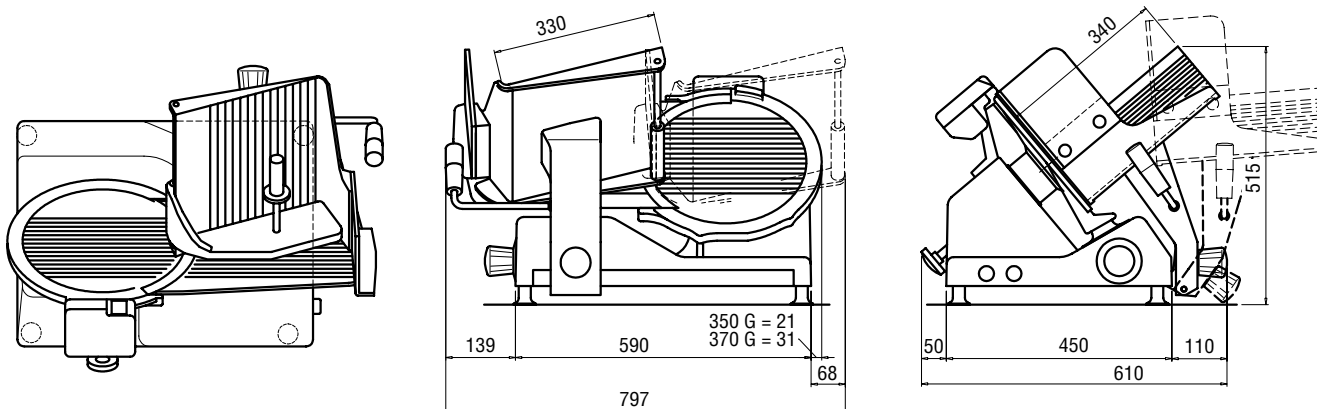

## SPECIFICHE TECNICHE - TECHNICAL SPECIFICATION

Diametro lama (mm)	Blade diameter (mm)	350
Motore	Motor	0,5 hp - 0,37 kw
Anello protezione inamovibile	Fixed protection ring	√
Comandi bassa tensione	Low tension devices	√
Blocco meccanico vela spessore	Gauge plate mechanical locking	√
Protezione acqua	Waterproof	IP 69
Normativa riferimento	Reference rule	UNI EN 1974
<b>CAPACITÀ DI TAGLIO - mm</b>	<b>CUTTING CAPACITY - mm</b>	
Rettangolo	Rectangular	260 x 155
Quadrato	Square	200 x 200
Tondo	Round	Ø 220
Apertura max	Max thickness	25
<b>PESO/IMBALLO</b>	<b>WEIGHT / PACKAGE</b>	
Peso netto	Net weight	40,3 kg
Peso imballato	Packed weight	46 kg
Dimensioni imballo cartone	Package dimensions cardboard	800 x 770 x 710 ht