

PMX 60 / 90

Impastatrici / Mixers

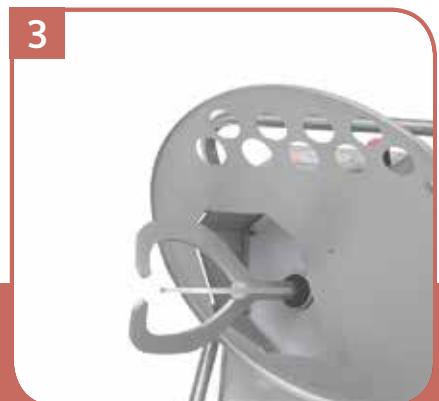

DOTAZIONI DI SERIE

- Costruite completamente in acciaio inox AISI 304
- Vasca raccolta prodotto ribaltabile con regolazione dei giri
- Vasca motorizzata
- Trasmissione con motoriduttore
- Pale velocità fissa asportabili
- Facilità nella pulizia

STANDARD EQUIPMENT

- Entirely in stainless steel 18/10
- Tipping bowl and bowl regulation turns
- Motorized hopper
- Closed hydraulic circuit with tank oil bath reducer (permanently oiled)
- Safety avoids the start when the arm is lifted up
- Extremely easy to clean

PMX 60

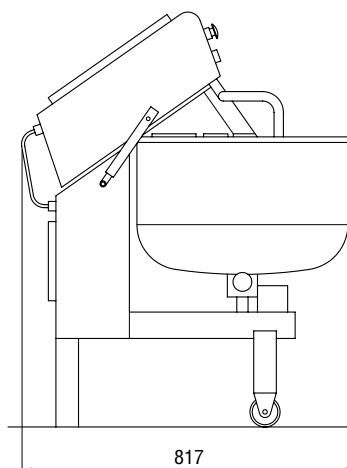
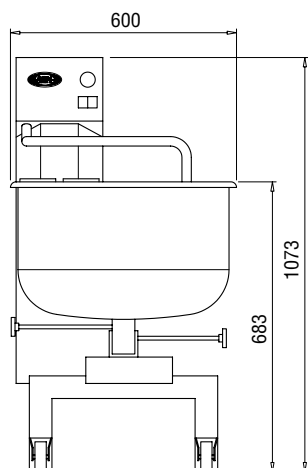

PMX 90

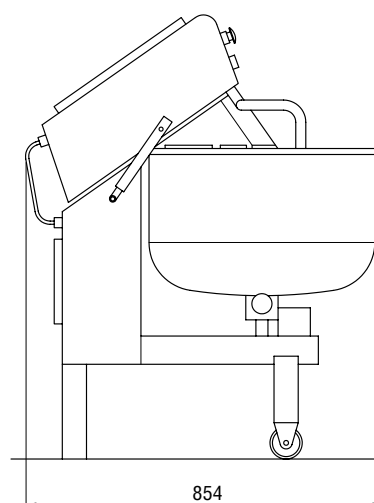
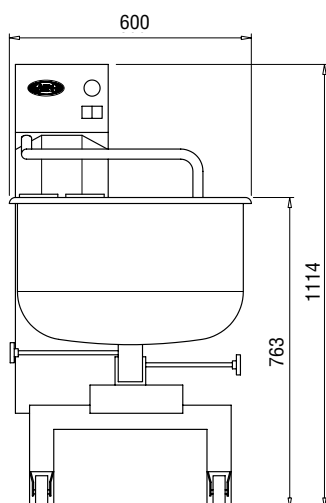

| SPECIFICHE TECNICHE / TECHNICAL SPECIFICATION | | PMX 60 | PMX 90 |
|---|-------------------------------|-----------|-----------|
| Capacità contenitori - litri | <i>Hopper - lt</i> | 60 | 90 |
| Capacità impasto | <i>Mixing capacity</i> | 8 - 35 kg | 8 - 50 kg |
| Motore kw | <i>Motor power kw</i> | 0,5 | 0,75 |
| Comandi bassa tensione | <i>24 Volts control panel</i> | √ | √ |
| Protezione acqua | <i>Water proof</i> | IP 65 | IP 65 |
| Peso Kg | <i>Weght kg</i> | 95 | 100 |