



HD 4000

Hamburgatrice / Patty former machine



DOTAZIONI DI SERIE

- Produzione variabile fino a 4000 pz/h
- Pulitore pneumatico integrato
- Ribassata per facilitarne il carico
- Contenitore 30 lt
- Vasca complementare - 80 lt
- Carrello supporto con ruote
- Nastro uscita 1127 mm
- Pedale
- Nessuna chiave richiesta per smontaggio parti

OPTIONAL

- Interfogliatore

STANDARD EQUIPMENT

- Variable productivity till 4000 patties per hour
- Pneumatic wire cleaner
- Lower to facilitate loading
- Hopper 30 lt
- Complementary hopper - 80 lt
- Support table with wheels
- Conveyor belt 1127 mm
- Foot switch
- No specific dismantling tools

OPTIONAL

- Paper attachment

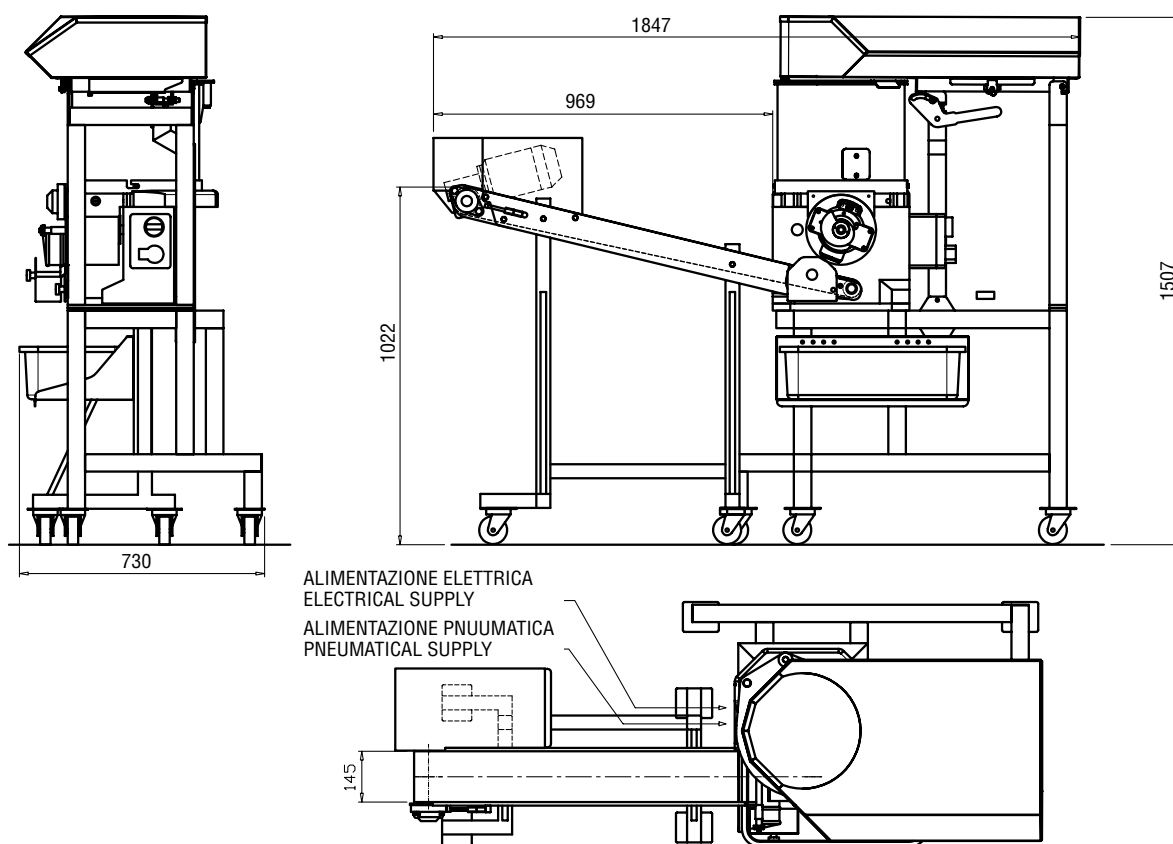

SPECIFICHE TECNICHE / TECHNICAL SPECIFICATION

Motore	Motor	Std (kw 0,75 tr)
Diametro Max foglio carta	Max paper dimension	135 x 135 mm
Diam. Max ottenibile stampo singolo circolare	Shape - max diam - single shape	130 mm
Diam. Max ottenibile stampo doppio circolare	Shape - max diam - double shape	55 mm
Dimensioni	Dimension	1847 x 730 x 1507
Peso netto	Net weight	130 kg
Peso imballato	Packed weight	275 kg
Dimensioni imballo legno	Wooden crate	1430 x 1320 x 1700 ht