

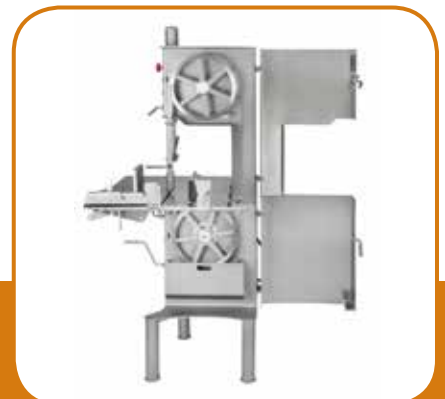

# ABM 350

Segaossi / Band saws machine

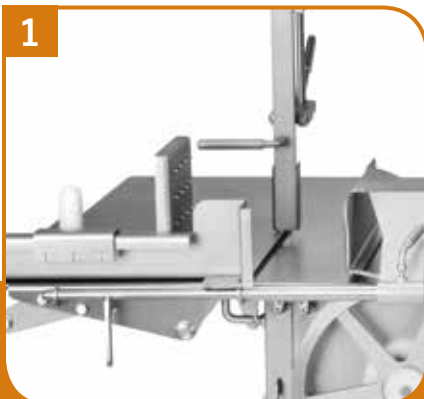

## DOTAZIONI DI SERIE

- Costruzione solida e robusta completamente in acciaio inox
- Tenditore lama automatico e porzionatore spessore taglio
- Pulegge in acciaio inox
- Guidalama superiore scorrevole sostenuta in posizione automatica
- Carrello scorrevole per una pulizia impeccabile, piedini regolabili
- Motore e materiale elettrico protetto dagli schizzi d'acqua
- Facile manutenzione e pulizia

## STANDARD EQUIPMENT

- *Heavy duty and compact, stainless steel machine*
- *Automatic blade tensioner and serving setter cuts*
- *Stainless steel tension pulley*
- *Sliding upper saw guide held in automatic position*
- *Moving carriage for a perfect cleaning, four adjustable leg*
- *Waterproof motor and electric equipment*
- *Very easy to maintain and clean*

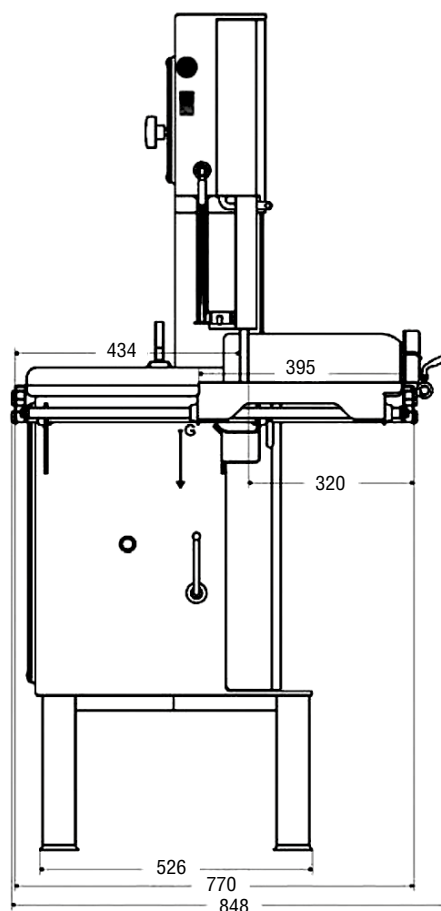
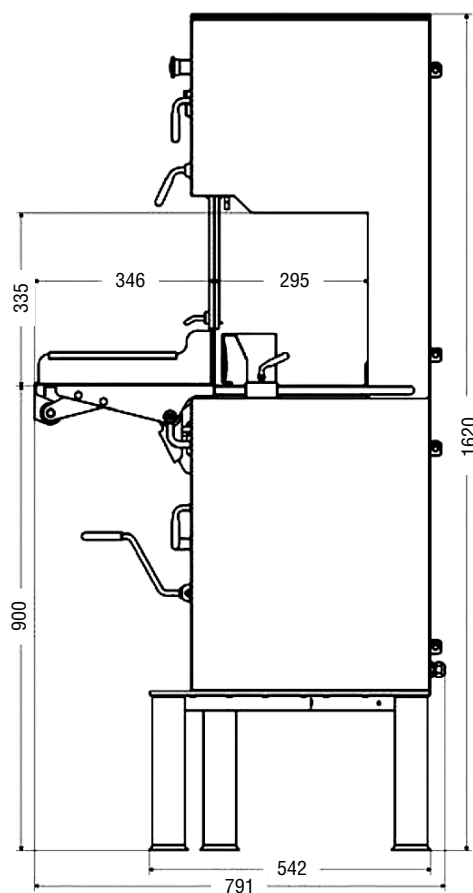

## SPECIFICHE TECNICHE / TECHNICAL SPECIFICATION

Capacità di taglio	<i>Cutting capacity</i>	300 x 340 ht
Piano lavoro	<i>Work top mm</i>	641 x 829
Diametro volani mm	<i>Wheel diam mm</i>	350
Sviluppo lama mm	<i>Blade standard mm</i>	2490
Motore kw	<i>Motor power kw</i>	2,5
Peso kg	<i>Weight kg</i>	140